



User's Manual

**1.200 W
ATA SOLAR INVERTER**

Table Of Contents

ABOUT THIS MANUAL	1
Purpose.....	1
Scope	1
SAFETY INSTRUCTIONS.....	1
INTRODUCTION	2
Features	2
Basic System Architecture.....	2
Product Overview.....	3
INSTALLATION	4
Unpacking and Inspection.....	4
Preparation.....	4
Mounting the Unit.....	4
Battery Connection.....	5
AC Input/Output Connection.....	7
PV Connection.....	8
Final Assembly.....	9
Communication Connection.....	9
OPERATION	10
Power ON/OFF	10
Operation and Display Panel.....	10
LCD Display Icons	11
LCD Setting.....	13
Display Setting	21
Operating Mode Description	24
Battery Equalization Description	26
Fault Reference Code.....	28
Warning Indicator	28
SPECIFICATIONS	29
Table 1 Line Mode Specifications	29
Table 2 Inverter Mode Specifications	30
Table 3 Charge Mode Specifications	31
Table 4 General Specifications	31
TROUBLE SHOOTING	32
Appendix: Approximate Back-up Time Table	33

ABOUT THIS MANUAL

Purpose

This manual describes the assembly, installation, operation and troubleshooting of this unit. Please read this manual carefully before installations and operations. Keep this manual for future reference.

Scope

This manual provides safety and installation guidelines as well as information on tools and wiring.

SAFETY INSTRUCTIONS



WARNING: This chapter contains important safety and operating instructions. Read and keep this manual for future reference

1. Before using the unit, read all instructions and cautionary markings on the unit, the batteries and all appropriate sections of this manual.
2. CAUTION --To reduce risk of injury, charge only deep-cycle lead acid type rechargeable batteries. Other types of batteries may burst, causing personal injury and damage.
3. Do not disassemble the unit. Take it to a qualified service center when service or repair is required. Incorrect re-assembly may result in a risk of electric shock or fire.
4. To reduce risk of electric shock, disconnect all wirings before attempting any maintenance or cleaning. Turning off the unit will not reduce this risk.
5. CAUTION - Only qualified personnel can install this device with battery.
6. NEVER charge a frozen battery.
7. For optimum operation of this inverter/charger, please follow required spec to select appropriate cable size. It's very important to correctly operate this inverter/charger.
8. Be very cautious when working with metal tools on or around batteries. A potential risk exists to drop a tool to spark or short circuit batteries or other electrical parts and could cause an explosion.
9. Please strictly follow installation procedure when you want to disconnect AC or DC terminals. Please refer to INSTALLATION section of this manual for the details.
10. One piece of 150A fuse is provided as over-current protection for the battery supply.
11. GROUNDING INSTRUCTIONS -This inverter/charger should be connected to a permanent grounded wiring system. Be sure to comply with local requirements and regulation to install this inverter.
12. NEVER cause AC output and DC input short circuited. Do NOT connect to the mains when DC input short circuits.
13. Warning!! Only qualified service persons are able to service this device. If errors still persist after following troubleshooting table, please send this inverter/charger back to local dealer or service center for maintenance.

INTRODUCTION

This is a multi-function inverter/charger, combining functions of inverter, solar charger and battery charger to offer uninterruptible power support with portable size. Its comprehensive LCD display offers user-configurable and easy-accessible button operation such as battery charging current, AC/solar charger priority, and acceptable input voltage based on different applications.

Features

- Pure sine wave inverter
- Configurable input voltage range for home appliances and personal computers via LCD setting
- Configurable battery charging current based on applications via LCD setting
- Configurable AC/Solar Charger priority via LCD setting
- Compatible to mains voltage or generator power
- Auto restart while AC is recovering
- Overload/ Over temperature/ short circuit protection
- Smart battery charger design for optimized battery performance
- Cold start function

Basic System Architecture

The following illustration shows basic application for this inverter/charger. It also includes following devices to have a complete running system:

- Generator or Utility.
- PV modules.

Consult with your system integrator for other possible system architectures depending on your requirements. This inverter can power all kinds of appliances in home or office environment, including motor-type appliances such as tube light, fan, refrigerator and air conditioner.

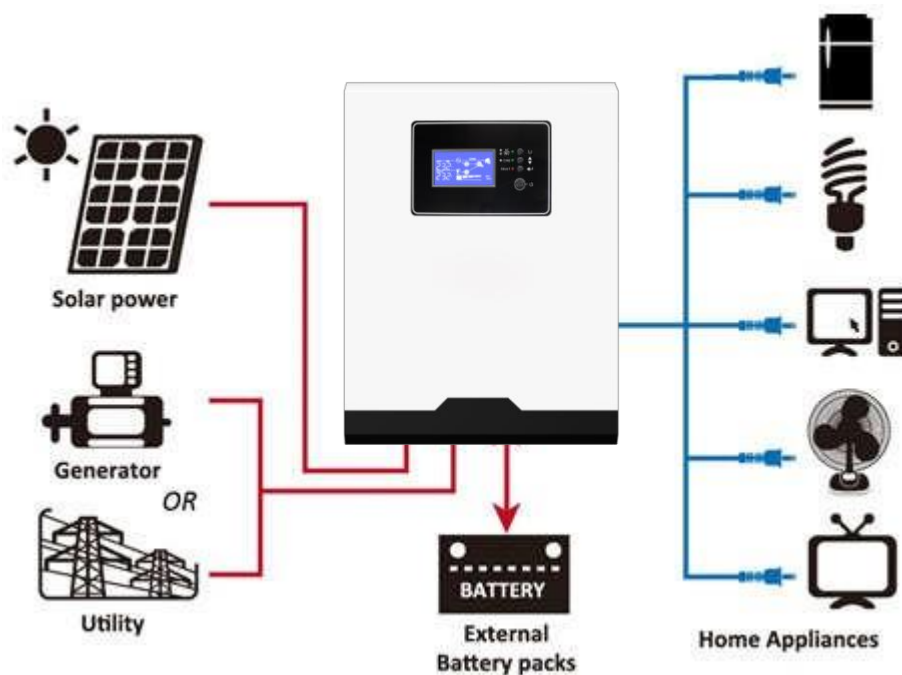
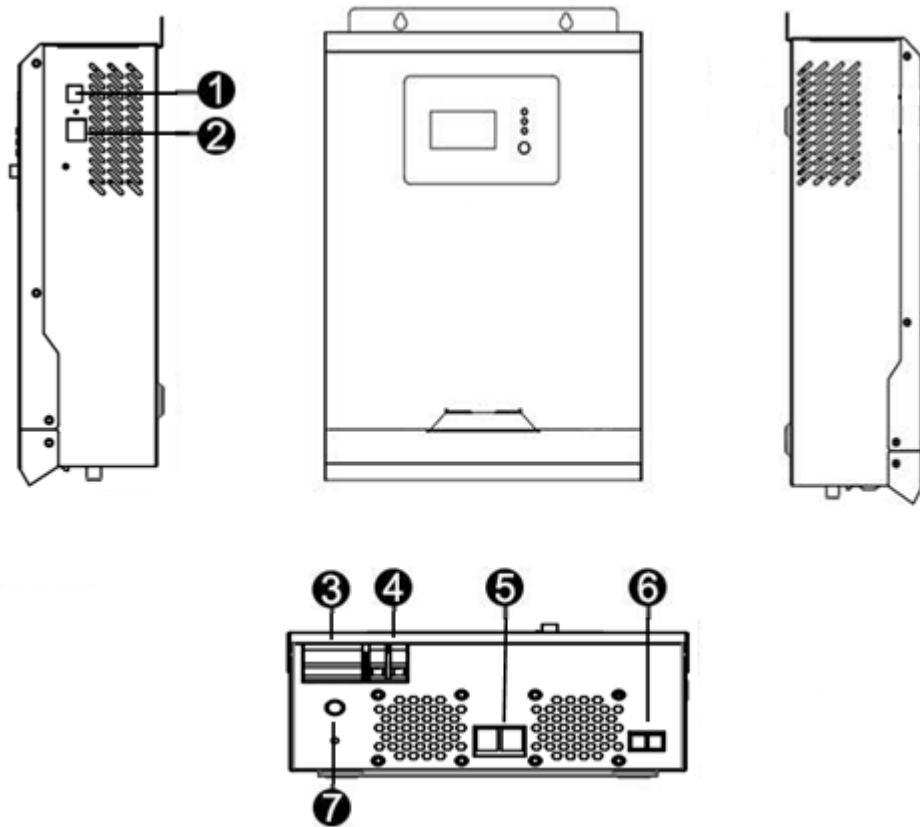

Figure 1 Hybrid Power System

Product Overview



1. USB communication port (Optional)
2. RS-232 communication port
3. AC input
4. AC output
5. Battery input
6. PV input
7. Fuse or Circuit breaker

INSTALLATION

Unpacking and Inspection

Before installation, please inspect the unit. Be sure that nothing inside the package is damaged. You should have received the following items inside of package:

- The unit x 1
- User manual x 1
- Communication cable x 2

Preparation

Before connecting all wirings, please take off bottom cover by removing the screws (2pcs as shown below)

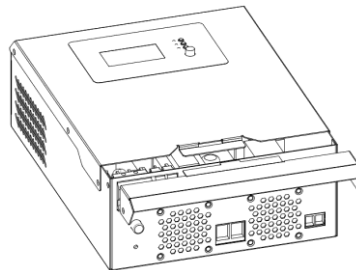

1.200 W

Mounting the Unit

Consider the following points before selecting where to install:

- Do not mount the inverter on flammable construction materials.
- Mount on a solid surface
- Install this inverter at eye level in order to allow the LCD display to be read at all times.
- For proper air circulation to dissipate heat, allow a clearance of approx. 20 cm to the side and approx. 50 cm above and below the unit.
- The ambient temperature should be between 0°C and 55°C to ensure optimal operation.
- The recommended installation position is to be adhered to the wall vertically.
- Be sure to keep other objects and surfaces as shown in the diagram to guarantee sufficient heat dissipation and to have enough space for removing wires.

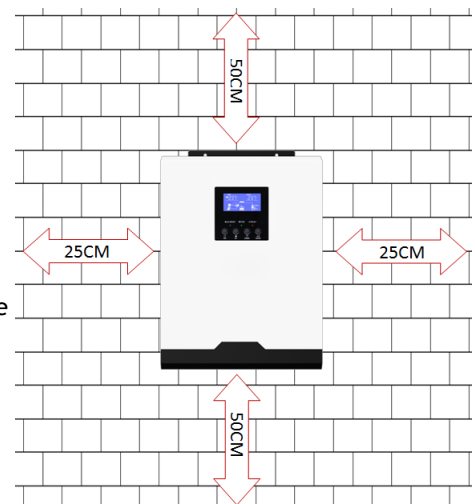

SUITABLE FOR MOUNTING ON CONCRETE OR OTHER NON-COMBUSTIBLE SURFACE ONLY.

Install the unit by screwing two screws. It's recommended to use M4 or M5 screws.



Battery connection

CAUTION: For safety operation and regulation compliance, it's requested to install a separate DC over-current protector or disconnect device between battery and inverter. It may not be requested to have a disconnect device in some applications, however, it's still requested to have over-current protection installed. Please refer

to typical amperage in below table as required fuse or breaker size.

WARNING! All wiring must be performed by qualified personnel.

WARNING! It's very important for system safety and efficient operation to use appropriate cable for battery connection. To reduce risk of injury, please use the proper recommended cable as below.

Recommended battery cable size:

Model	Typical Amperage	Wire Size	Terminal			Torque Value
			Cable mm ²	Dimensions		
				D (mm)	L (mm)	
1.2KW	114A	1 x 4AWG	25	/	/	2~ 3 Nm

Battery connection for 1.2KW:

Please follow below steps to implement battery connection:

1. Remove insulation sleeve 18 mm for positive and negative conductors.
2. Suggest to put bootlace ferrules on the end of positive and negative wires with a proper crimping tool.
3. 1200 W model supports 12VDC system. Connect all battery packs as below chart. It's suggested to connect at least 100Ah capacity battery.

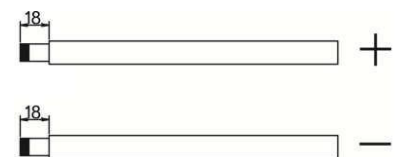

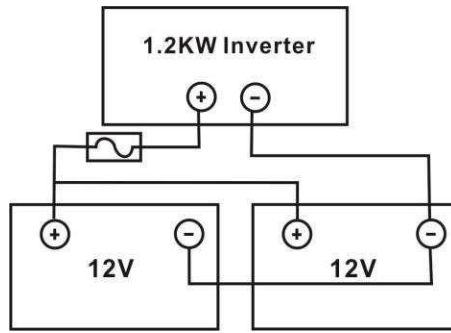

4. Insert the battery wires flatly into battery connectors of inverter and make sure the bolts are tightened with torque of 2 Nm in clockwise direction. Make sure polarity at both the battery and the inverter/charge is correctly connected and conductors are tightly screwed into the battery terminals.

Recommended tool: #2 Pozzi Screwdriver

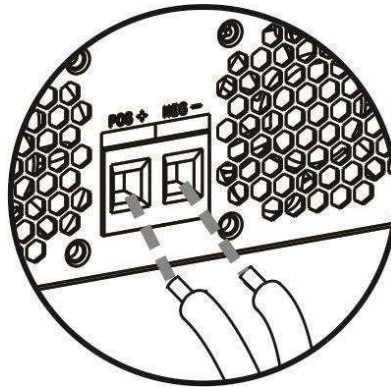

WARNING: Shock Hazard

Installation must be performed with care due to high battery voltage in series.



CAUTION!!

Before making the final DC, connection or closing DC breaker/disconnector, be sure positive (+) must be connected to positive (+) and negative (-) must be connected to negative (-)

AC Input/output Connection

CAUTION!! Before connecting to AC input power source, please install a separate AC breaker between inverter and AC input power source. This will ensure the inverter can be securely disconnected during maintenance and fully protected from over current of AC input. The recommended spec of AC breaker is 10A for 1200 W

CAUTION!! There are two terminal blocks with “AC IN” and “AC OUT” markings. Please do NOT mis-connect input and output connectors.

WARNING! All wiring must be performed by qualified personnel.

WARNING! It's very important for system safety and efficient operation to use appropriate cable for AC input connection. To reduce risk of injury, please use the proper recommended cable size as below.

Suggested cable requirement for AC wires

Model	Gauge	Cable (mm ²)	Torque Value
1.200 W	16 AWG	1.5	0.6 Nm

Please follow below steps to implement AC input/output connection:

1. Before making AC input/output connection, be sure to open DC protector or disconnecter first.
2. Remove insulation sleeve 10mm for 5 conductors for 1200 W model
3. For 1200 W models, insert AC input wires according to polarities indicated on terminal block and tighten the terminal screws. Be sure to connect PE protective conductor (⊕) first.

⊕ → Ground (yellow-green)
L → LINE (brown or black)
N → Neutral (blue)

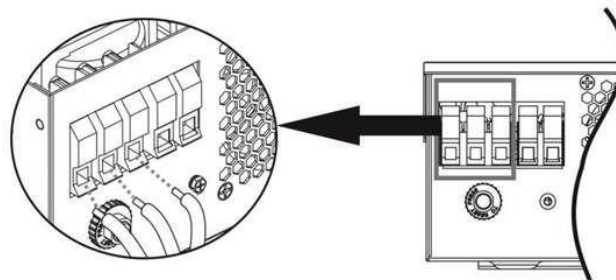

1200 W



WARNING: Be sure that AC power source is disconnected before attempting to hardwire it to the unit.

4. Then, insert AC output wires according to polarities indicated on terminal block and tighten terminal screws.

⊕ → Ground (yellow-green)
L → LINE (brown or black)
N → Neutral (blue)

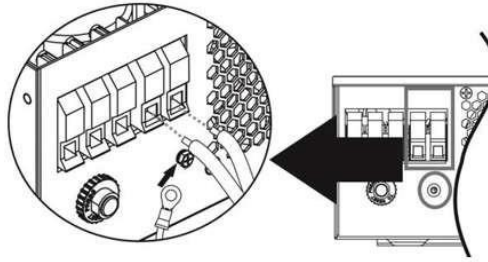

1.200 W

5. Make sure the wires are securely connected.

CAUTION: Appliances such as air conditioner are required at least 2-3 minutes to restart because it's required to have enough time to balance refrigerant gas inside of circuits. If a power shortage occurs and recovers in a short time, it will cause damage to your connected appliances. To prevent this kind of damage, please check manufacturer of air conditioner if it's equipped with time-delay function before installation. Otherwise, this inverter/charger will trig overload fault and cut off output to protect your appliance but sometimes it still causes internal damage to the air conditioner.

PV Connection

CAUTION: It is forbidden for inverter to share the same solar panel group.

CAUTION: Before connecting to PV modules, please install separately a DC circuit breaker between inverter and PV modules.

WARNING! It's very important for system safety and efficient operation to use appropriate cable for PV module connection. To reduce risk of injury, please use the proper recommended cable size as below.

Wire Size	Cable (mm ²)	Torque value (max)
1 x 8AWG	10	1.6 Nm

When selecting proper PV modules, please be sure to consider below parameters:

1. Open circuit Voltage (Voc) of PV modules not exceeds max. PV array open circuit voltage of inverter.
2. Open circuit Voltage (Voc) of PV modules should be higher than min. battery voltage.

INVERTER MODEL	1.200 W
Max. PV Array Open Circuit Voltage	102Vdc
PV Array MPPT Voltage Range	15Vdc~80Vdc

Take 300Wp PV module as an example. After considering above two parameters, the recommended module configurations listed as below table.

Maximum Power (Pmax)	300W	For 1200 W: 2 sets in parallel
Max. Power Voltage Vmpp(V)	32V	
Max. Power Current Impp(A)	9.4A	
Open Circuit Voltage Voc(V)	40V	
Short Circuit Current Isc(A)	10A	

PV Module Wire Connection

Please follow below steps to implement PV module connection:

1. Remove insulation sleeve 10 mm for positive and negative conductors.
2. Suggest to put bootlace ferrules on the end of positive and negative wires with a proper crimping tool.
3. Check correct polarity of wire connection from PV modules and PV input connectors. Then, connect positive pole (+) of connection wire to positive pole (+) of PV input connector. Connect negative pole (-) of connection wire to negative pole (-) of PV input connector. Screw two wires tightly in clockwise direction.

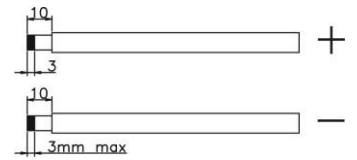

Recommended tool: 4mm blade screwdriver

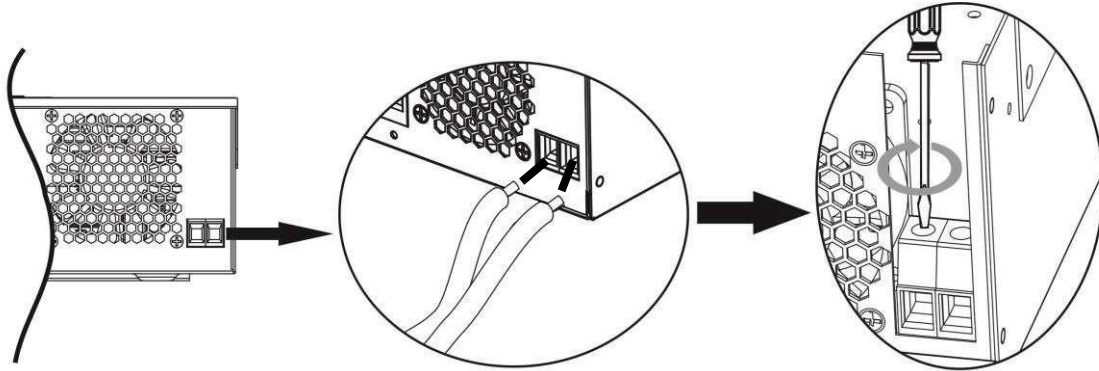

1.200 W Model

Final Assembly

After connecting all wirings, please put bottom cover back by screwing the screws as shown below.

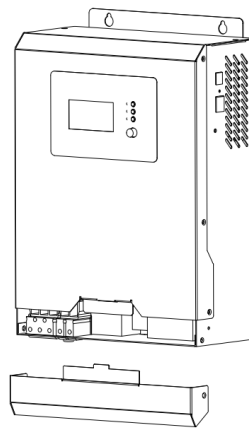

1200 W model

Communication Connection

Please use supplied communication cable to connect to inverter to PC and please download and install the software from www.tecnaware.com/software/watchpower.



Operation Power

Operation and Display Panel

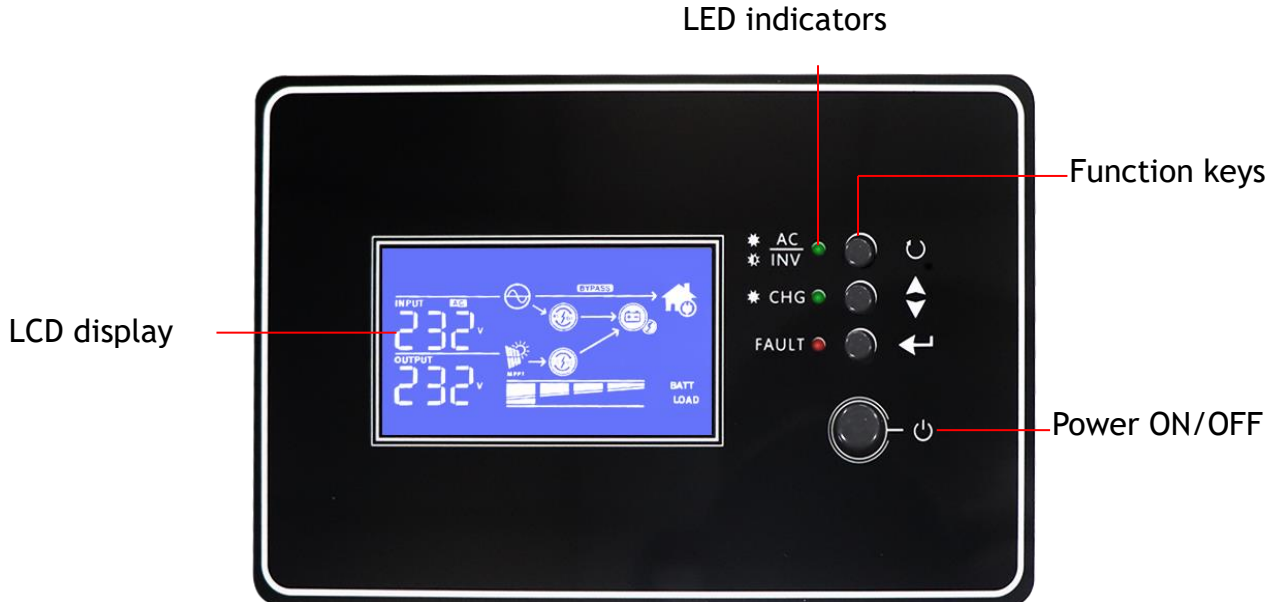

The operation and display panel, shown in below chart, is on the front panel of the inverter. It includes three indicators, four function keys and an LCD display, indicating the operating status and input/output power information.



LED Indicator

LED Indicator			Messages
	Green	Solid On	Output is powered by utility in Line Mode.
		Flashing	Output is powered by battery or PV in Battery mode.
	Green	Solid On	Battery is fully charged.
		Flashing	Battery is charging.
FAULT	Red	Solid On	Fault occurs in the inverter.
		Flashing	Warning condition occurs in the inverter.

Function Keys





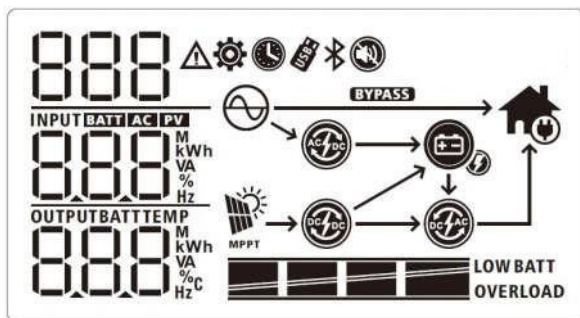



Function Key	Description
	ESC To exit setting mode
	SCROLL To go to next selection
	ENTER To confirm the selection in setting mode or enter setting mode

LCD Display Icons

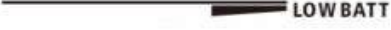

Icon	Function description	
Input Source Information		
	Indicates the AC input.	
	Indicates the PV input	
	Indicate input voltage, input frequency, PV voltage, charger current, charger power, battery voltage.	
Configuration Program and Fault Information		
	Indicates the setting programs.	
	Indicates the warning and fault codes. Warning: flashing with warning code. Fault: lighting with fault code	
Output Information		
	Indicate output voltage, output frequency, load percent, load in VA, load in Watt and discharging current.	
Battery Information		
	Indicates battery level by 0-24%, 25-49%, 50-74% and 75-100% in battery mode and charging status in line mode.	
In AC mode, it will present battery charging status.		
Status	Battery voltage	LCD Display
Constant Current mode / Constant Voltage mode	<2V/cell	4 bars will flash in turns.
	2 ~ 2.083V/cell	Bottom bar will be on and the other three bars will flash in turns.
	2.083 ~ 2.167V/cell	Bottom two bars will be on and the other two bars will flash in turns.
	> 2.167 V/cell	Bottom three bars will be on and the top bar will flash.
Floating mode. Batteries are fully charged.		4 bars will be on.





In battery mode, it will present battery capacity.

Load Percentage	Battery Voltage	LCD Display
Load >50%	< 1.85V/cell	 LOW BATT
	1.85V/cell ~ 1.933V/cell	 BATT
	1.933V/cell ~ 2.017V/cell	 BATT
	> 2.017V/cell	 BATT
Load < 50%	< 1.892V/cell	 LOW BATT
	1.892V/cell ~ 1.975V/cell	 BATT
	1.975V/cell ~ 2.058V/cell	 BATT
	> 2.058V/cell	 BATT

Load Information

OVERLOAD	Indicates overload.	
	Indicates the load level by 0-24%, 25-49%, 50-74% and 75-100%.	
	0%-24%	25%-49%
	50%-74%	75%-100%

Mode Operation Information

	Indicates unit connects to the mains.
	Indicates unit connects to the PV panel.
BYPASS	Indicates load is supplied by utility power.
	Indicates the utility charger circuit is working.
	Indicates the solar charger circuit is working.
	Indicates the DC/AC inverter circuit is working.

Mute Operation

	Indicates unit alarm is disabled.
---	-----------------------------------

LCD Setting













After pressing and holding “ ← ” button for 3 seconds, the unit will enter setting mode. Press “ ⬆ ” button to select setting programs. And then, press “ ← ” button to confirm the selection or “ ↻ ” button to exit.





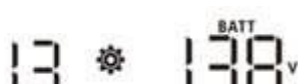

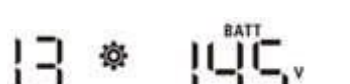



Setting Programs:

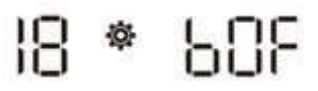

Program	Description	Selectable option
00	Exit setting mode	Escape 00 ⚙ ESC
01	Output source priority: To configure load power source priority	Utility first (default) 01 ⚙ UTI Utility will provide power to the loads as first priority. Solar and battery energy will provide power to the loads only when utility power is not available.
		Solar first 01 ⚙ SOL Solar energy provides power to the loads as first priority. If solar energy is not sufficient to power all connected loads, battery energy will supply power the loads at the same time. Utility provides power to the loads only when any one condition happens: - Solar energy is not available - Battery voltage drops to low-level warning voltage or the setting point in program 12.
		SBU priority 01 ⚙ SBU Solar energy provides power to the loads as first priority. If solar energy is not sufficient to power all connected loads, battery energy will supply power to the loads at the same time. Utility provides power to the loads only when battery voltage drops to either low-level warning voltage or the setting point in program 12.

02	Maximum charging current: To configure total charging current for solar and utility chargers. (Max. charging current = utility charging current + solar charging current)	10A (for 1.200 W)	20A
		02 * 10A	02 * 20A
		30A	40A (default for 1.200 W)
		02 * 30A	02 * 40A
03	AC input voltage range	Appliances (default)	If selected, acceptable AC input voltage range will be within 90-280VAC.
		03 * APL	
05	Battery type	UPS	If selected, acceptable AC input voltage range will be within 170-280VAC.
		03 * UPS	
05	Battery type	AGM (default)	Flooded
		05 * AGM	05 * FLd
		User-Defined	If "User-Defined" is selected, battery charge voltage and low DC cut-off voltage can be set up in program 26, 27 and 29.
		05 * USE	

06	Auto restart when overload occurs	Restart disable (default) 06 * LFD	Restart enable 06 * LFE
07	Auto restart when over temperature occurs	Restart disable (default) 07 * LFD	Restart enable 07 * LFE
09	Output frequency	50Hz (default) 09 * 50 _{Hz}	60Hz 09 * 60 _{Hz}
11	Maximum utility charging current Note: If setting value in program 02 is smaller than that in program in 11, the inverter will apply charging current from program 02 for utility charger.	Available options:	
		10A 11 * 10A	20A (default) 11 * 20A
12	Setting voltage point back to utility source when selecting "SBU priority" or "Solar first" in program 01.	Available options:	
		11.0V 12 * 11.0 ^v _{TBATT}	11.3V 12 * 11.3 ^v _{TBATT}
		11.5V (default) 12 * 11.5 ^v _{TBATT}	11.8V 12 * 11.8 ^v _{TBATT}
		12.0V 12 * 12.0 ^v _{TBATT}	12.3V 12 * 12.3 ^v _{TBATT}
12.5V 12 * 12.5 ^v _{TBATT}	12.8V 12 * 12.8 ^v _{TBATT}		

13	Setting voltage point back to battery mode when selecting "SBU priority" or "Solar first" in program 01.	Available options:	
		Battery fully charged	12.0V
			
		12.3V	12.5V
			
		12.8V	13.0V
			
13.3V	13.5V (default)		
			
13.8V	14.0V		
			
14.3V	14.5V		
			
16	Charger source priority: To configure charger source priority	If this inverter/charger is working in Line, Standby or Fault mode, charger source can be programmed as below:	
		Solar first	Solar energy will charge battery as first priority. Utility will charge battery only when solar energy is not available
			

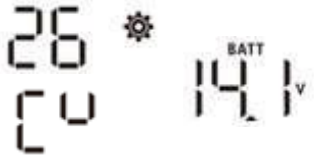
16	Charger source priority: To configure charger source priority	Utility first 	Utility will charge battery as first priority. Solar energy will charge battery only when utility power is not available.
		Solar and Utility (default) 	Solar energy and utility will charge battery at the same time.
		Only Solar 	Solar energy will be the only charger source no matter utility is available or not.
		If this inverter/charger is working in Battery mode, only solar energy can charge battery. Solar energy will charge battery if it's available and sufficient.	
18	Alarm control	Alarm on (default) 	Alarm off 
19	Auto return to default display screen	Return to default display screen (default) 	If selected, no matter how users switch display screen, it will automatically return to default display screen (Input voltage /output voltage) after no button is pressed for 1 minute.
		Stay at latest screen 	If selected, the display screen will stay at latest screen user finally switches.
20	Backlight control	Backlight on (default) 	Backlight off 
22	Beeps while primary source is interrupted	Alarm on (default) 	Alarm off 

23	Overload bypass: When enabled, the unit will transfer to line mode if overload occurs in battery mode.	Bypass disable (default) 23 * bYd	Bypass enable 23 * bYE
25	Record Fault code	Record enables (default) 25 * FEN	Record disables 25 * FdS
26	Bulk charging voltage (C.V voltage)	1.200 W default setting: 14.1V  If self-defined is selected in program 5, this program can be set up. Setting range is from 12.5V to 15.0V. Increment of each click is 0.1V.	
27	Floating charging voltage	1.200 W default setting: 13.5V  If self-defined is selected in program 5, this program can be set up. Setting range is from 12.5V to 15.0V. Increment of each click is 0.1V.	
29	Low DC cut-off voltage	1.200 W default setting: 10.5V  If self-defined is selected in program 5, this program can be set up. Setting range is from 10.5V to 12.0V. Increment of each click is 0.1V. Low DC cut-off voltage will be fixed to setting value no matter what percentage of load is connected.	
30	Battery equalization	Enable 30 * EEN	Disable (default) 30 * EdS
If "Flooded" or "User-Defined" is selected in program 05, this program can be set up.			

31	Battery equalization voltage	1.200 W default setting: 14.6V 31 ⚙️ EV BATT 14.6V	
		Setting range is from 12.5V to 15.0V. Increment of each click is 0.1V.	
33	Battery equalized time	60min (default) 33 ⚙️ 60	Setting range is from 5min to 900min. Increment of each click is 5min.
34	Battery equalized timeout	120min (default) 33 ⚙️ 120	Setting range is from 5min to 900 min. Increment of each click is 5 min.
35	Equalization interval	30days (default) 35 ⚙️ 30d	Setting range is from 0 to 90 days. Increment of each click is 1 day
36	Equalization activated immediately	Enable 36 ⚙️ AEN	Disable (default) 36 ⚙️ AD5
		If equalization function is enabled in program 30, this program can be set up. If “Enable” is selected in this program, it’s to activate battery equalization immediately and LCD main page will show “EV”. If “Disable” is selected, it will cancel equalization function until next activated equalization time arrives based on program 35 setting. At this time, “EV” will not be shown in LCD main page.	

Display Setting



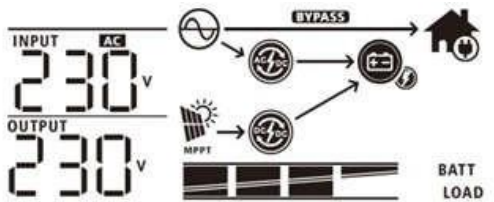
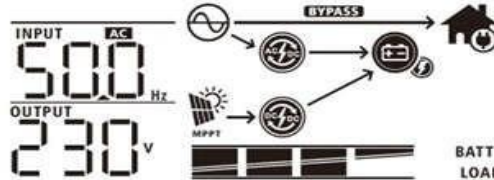
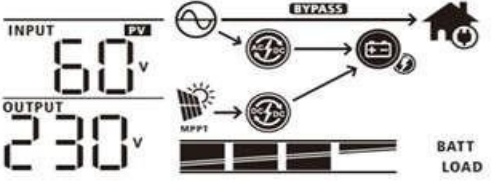
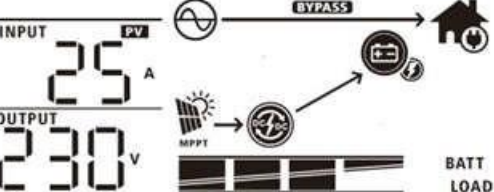
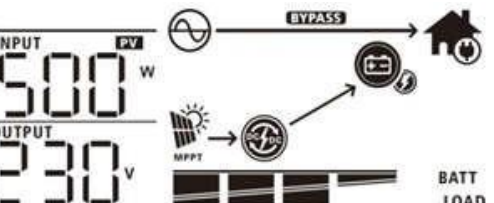
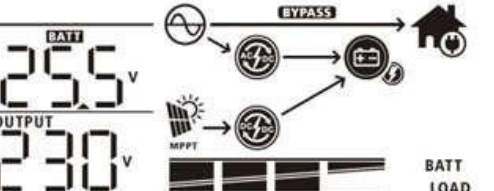

The LCD display information will be switched in turns by pressing “” button. The selectable information is switched as the following table in order.

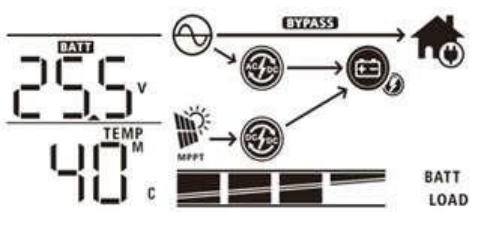
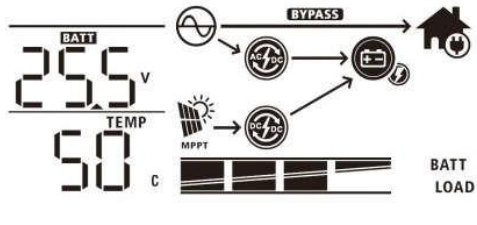
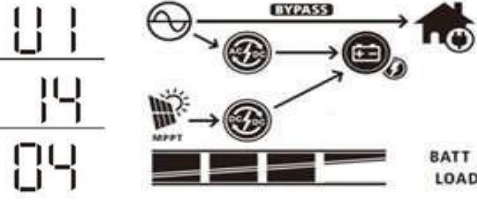
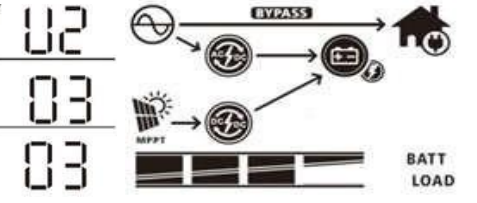
Selectable information	LCD display
Input voltage/Output voltage (Default Display Screen)	<p>Input Voltage=230V, output voltage=230V</p> 
Input frequency	<p>Input frequency=50Hz</p> 
PV voltage	<p>PV voltage=60V</p> 
PV charging current	<p>PV charging current = 25A</p> 
PV charging power	<p>PV charging power = 500W</p> 
Battery voltage and output voltage	<p>Battery voltage=25.5V, output voltage=230V</p> 

<p>Output frequency</p>	<p>Output frequency=50Hz</p>
<p>Load percentage</p>	<p>Load percent=70%</p>
<p>Load in VA</p>	<p>When connected load is lower than 1kVA, load in VA will present xxxVA like below chart.</p> <p>When load is larger than 1kVA ($\geq 1\text{kVA}$), load in VA will present x.xkVA like below chart.</p>
<p>Load in Watt</p>	<p>When load is lower than 1kW, load in W will present xxxW like below chart.</p> <p>When load is larger than 1kW ($\geq 1\text{kW}$), load in W will present x.xkW like below chart.</p>

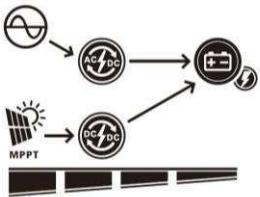
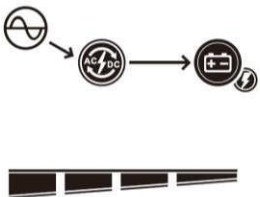
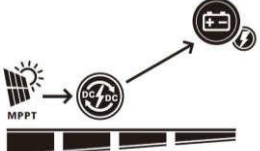
<p>Battery voltage/Inverter temperature and Solar charger controller temperature inside (Inverter temperature and SCC temperature is displayed in turns)</p>	<p>Battery voltage=25.5V, Inverter temperature =50°C</p>  <p>Battery voltage=25.5V, SCC temperature =40°C</p> 
<p>Main CPU version checking.</p>	<p>Main CPU version 00014.04.</p> 
<p>Secondary CPU version checking.</p>	<p>Secondary CPU version 00003.03.</p> 

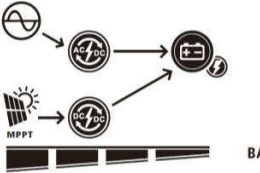
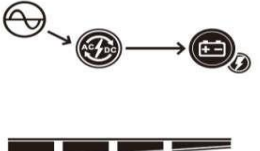
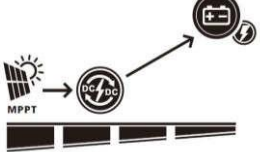
Operating Mode Description

Operation mode	Description	LCD display
<p>Standby mode</p> <p>Note:</p> <p>*Standby mode: The inverter is not turned on yet but at this time, the inverter can charge battery without AC output.</p>	<p>No output is supplied by the unit but it still can charge batteries.</p>	<p>Charging by utility and PV energy.</p> 
		<p>Charging by utility.</p> 
		<p>Charging by PV energy.</p> 
		<p>No charging.</p> 
<p>Fault mode</p> <p>Note:</p> <p>*Fault mode: Errors are caused by inside circuit error or external reasons such as over temperature, output short circuited and so on.</p>	<p>PV energy and utility can charge batteries.</p>	<p>Charging by utility and PV energy.</p> 
		<p>Charging by utility.</p> 
		<p>Charging by PV energy.</p> 
		<p>No charging.</p> 

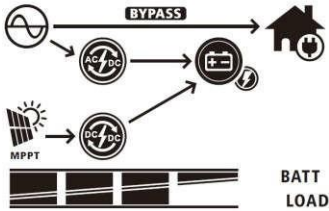
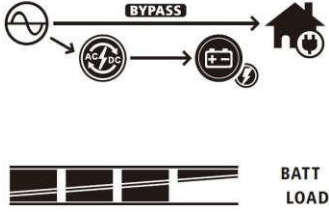
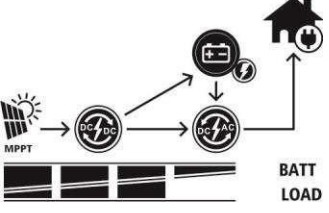
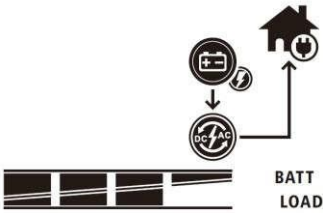
<p>Line Mode</p>	<p>The unit will provide output power from the mains. It will also charge the battery at line mode.</p>	<p>Charging by utility and PV energy.</p>  <p>Charging by utility.</p> 
<p>Battery Mode</p>	<p>The unit will provide output power from battery and PV power.</p>	<p>Power from battery and PV energy.</p>  <p>Power from battery only.</p> 

Battery Equalization Description

Equalization function is added into charge controller. It reverses the buildup of negative chemical effects like stratification, a condition where acid concentration is greater at the bottom of the battery than at the top. Equalization also helps to remove sulfate crystals that might have built up on the plates. If left unchecked, this condition, called sulfation, will reduce the overall capacity of the battery. Therefore, it's recommended to equalize battery periodically.

● How to Apply Equalization Function

You must enable battery equalization function in monitoring LCD setting program 30 first. Then, you may apply this function in device by either one of following methods:

1. Setting equalization interval in program 35.
2. Active equalization immediately in program 36.

● When to Equalize

In float stage, when the setting equalization interval (battery equalization cycle) is arrived, or equalization is active immediately, the controller will start to enter Equalize stage.

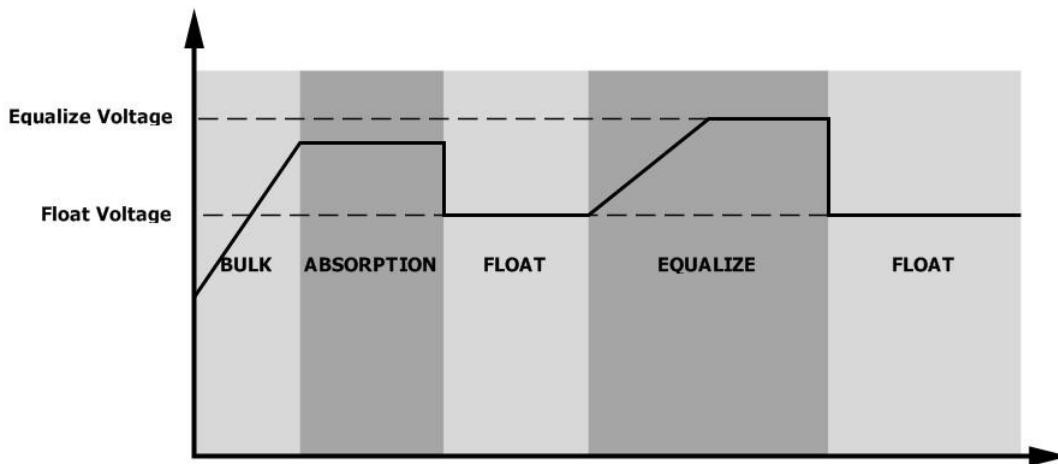

● Equalize charging time and timeout

In Equalize stage, the controller will supply power to charge battery as much as possible until battery voltage raises to battery equalization voltage. Then, constant-voltage regulation is applied to maintain battery voltage at the battery equalization voltage. The battery will remain in the Equalize stage until setting battery equalized time is arrived.

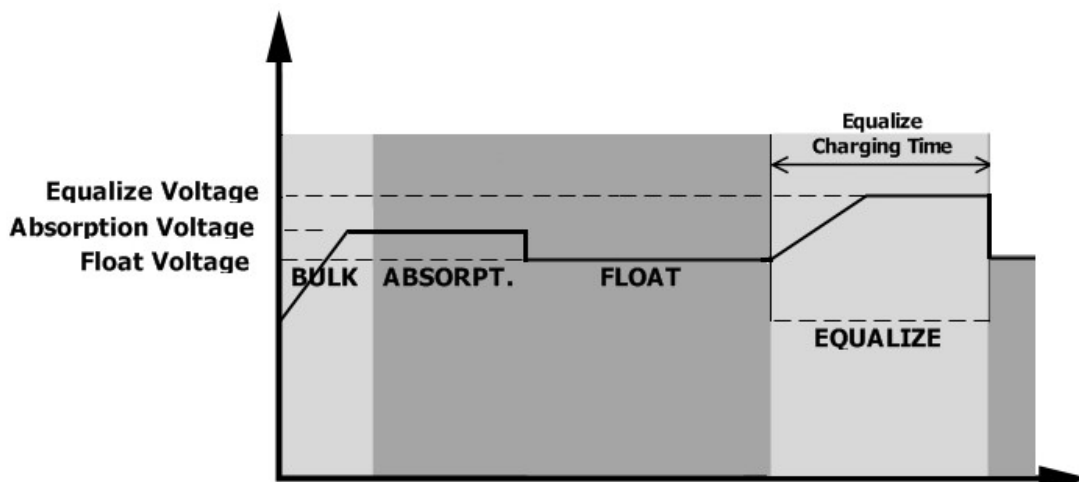

However, in Equalize stage, when battery equalized time is expired and battery voltage doesn't rise to battery equalization voltage point, the charge controller will extend the battery equalized time until battery voltage achieves battery equalization voltage. If battery voltage is still lower than battery equalization voltage when battery equalized timeout setting is over, the charge controller will stop equalization and return to float stage.

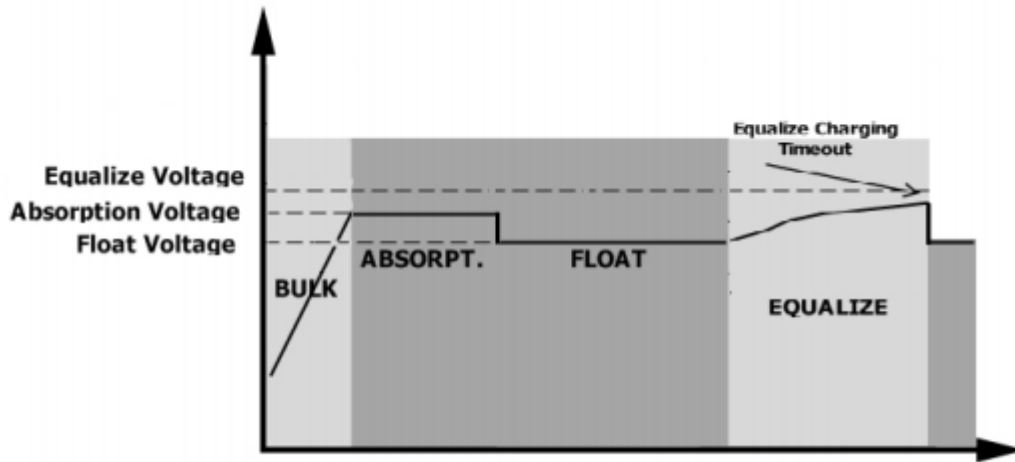

Fault Reference Code

Fault Code	Fault Event	Icon on
02	Over temperature	F02
03	Battery voltage is too high	F03
04	Battery voltage is too low	F04
05	Output short circuited or over temperature is detected by internal converter components.	F05
06	Output voltage is abnormal.	F06
07	Overload time out	F07
08	Bus voltage is too high	F08
09	Bus soft start failed	F09
12	NTC temperature sensor on the heatsink is failed	F 12

Warning Indicator

Warning Code	Warning Event	Audible Alarm	Icon flashing
02	Temperature of inverter inside is high	1. No beep when temperature is in high level. 2. Beep once every 0.5 second when temperature is increased to close to over-temperature protection.	02 [△]
03	Battery is over-charged	Beep once every second	03 [△]
04	Low battery	Beep once every second	04 [△]
07	Overload	Beep once every 0.5 second	07 [△]
10	Output power derating	Beep twice every 3 seconds	10 [△]
E9	Battery equalization	None	E9 [△]
20	Communication error between MPPT SCC board and main board	None	20 [△]
21	MPPT solar charger board cannot match with main board even communication is normal.	None	21 [△]

SPECIFICATIONS

Table 1 Line Mode Specifications

INVERTER MODEL	1.2KW
Input Voltage Waveform	Sinusoidal (utility or generator)
Nominal Input Voltage	230Vac
Low Loss Voltage	170Vac±7V (UPS); 90Vac±7V (Appliances)
Low Loss Return Voltage	180Vac±7V (UPS); 100Vac±7V (Appliances)
High Loss Voltage	280Vac±7V
High Loss Return Voltage	270Vac±7V
Max AC Input Voltage	300Vac
Nominal Input Frequency	50Hz / 60Hz (Auto detection)
Low Loss Frequency	40±1Hz
Low Loss Return Frequency	42±1Hz
High Loss Frequency	65±1Hz
High Loss Return Frequency	63±1Hz
Output Short Circuit Protection	Circuit Breaker
Efficiency (Line Mode)	>95% (Rated R load, battery full charged)
Transfer Time	10ms typical (UPS); 20ms typical (Appliances)
<p>Output power derating: When AC input voltage drops to 170V, the output power will be derated.</p>	<p>The graph plots Output Power on the vertical axis against Input Voltage on the horizontal axis. The horizontal axis has markers at 90V, 170V, and 280V. The vertical axis has markers for 50% Power and Rated Power. The power curve is zero for input voltages below 90V. At 90V, the power jumps to 50% of the rated power. From 90V to 170V, the power increases linearly to reach the full Rated Power. From 170V to 280V, the output power remains constant at the Rated Power level. Above 280V, the power drops to zero.</p>

Table 2 Inverter Mode Specifications

INVERTER MODEL	1200 W
Rated Output Power	1.2KVA/1.2KW
Output Voltage Waveform	Pure Sine Wave
Output Voltage Regulation	230Vac±5%
Output Frequency	50Hz
Peak Efficiency	93%
Overload Protection	5s@≥130% load; 10s@105%-130% load
Surge Capacity	2* rated power for 5 seconds
Nominal DC Input Voltage	12Vdc
Cold Start Voltage	11.5Vdc
Low DC Warning Voltage @ load < 50% @ load ≥ 50%	11.5Vdc 11.0Vdc
Low DC Warning Return Voltage @ load < 50% @ load ≥ 50%	11.7Vdc 11.5Vdc
Low DC Cut-off Voltage @ load < 50% @ load ≥ 50%	10.7Vdc 10.5Vdc
High DC Recovery Voltage	15Vdc
High DC Cut-off Voltage	16Vdc
No Load Power Consumption	<25W

Table 3 Charge Mode Specifications

Utility Charging Mode		
INVERTER MODEL	1200 W	
Charging Algorithm	3 - Step	
AC Charging Current (Max)	20 Amp (@VI/P=230Vac)	
Bulking Charging Voltage	Flooded Battery	14.6
	AGM / Gel Battery	14.1
Floating Charging Voltage	13.5 Vdc	
Charging Curve	<p>The graph illustrates the charging curve for a battery cell. The y-axis represents Battery Voltage (per cell) and Charging Current (%). The x-axis represents Time. The curve is divided into three stages: Bulk (Constant Current), Absorption (Constant Voltage), and Maintenance (Floating). The Bulk stage shows a linear increase in voltage from 2.25Vdc to 2.43Vdc (2.35Vdc) and a constant current. The Absorption stage shows a constant voltage of 2.43Vdc (2.35Vdc) and a decreasing current. The Maintenance stage shows a constant voltage of 2.25Vdc and a very low current. Time intervals T0 and T1 are marked, with T1 = 10 * T0, minimum 10mins, maximum 8hrs.</p>	
MMPT Solar Charging Mode		
INVERTER MODEL	1200 W	
Max PV Array Power	700 W	
Charging Current	50 Amp	
PV Array MPPT Voltage Range	15Vdc ~ 80 Vdc	
Max. PV Array Open Circuit Voltage	102 Vdc	
Max Charging Current (AC charger plus solar charger)	60 Amp	

Table 4 General Specifications

INVERTER MODEL	1.2KW
Operating Temperature Range	-10°C to 50°C
Storage temperature	-15°C to 60°C
Humidity	5% to 95% Relative Humidity (Non-condensing)
Dimension (L x W x H), mm	320*240*105
Net Weight, KG	4.6

Installation dimension drawing

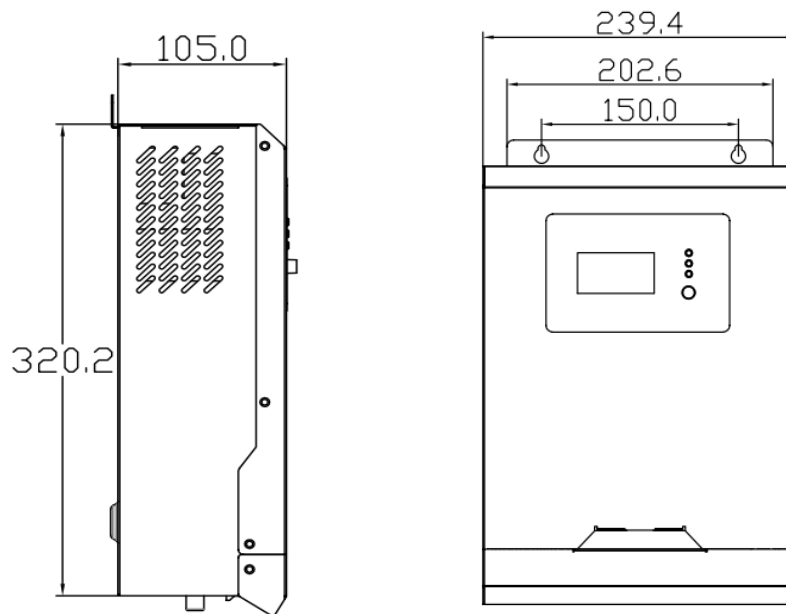

1200 W models installation dimension drawing

TROUBLE SHOOTING

Problem	LCD/LED/Buzzer	Explanation / Possible cause	What to do
Warning code 02 is displayed in the LCD.	No beep but it shows warning code 02 in the LCD.	Temperature of inverter inside is high.	1. Remove the loads. 2. Reduce the operation environment temperature.
	Beep once every 0.5 second and it shows warning code 02 in the LCD.		
Unit shuts down automatically during startup process.	LCD/LEDs and buzzer will be active for 3 seconds and then complete off.	The battery voltage is too low (<1.91V/Cell)	1. Re-charge battery. 2. Replace battery.
No response after power on.	No indication.	1. The battery voltage is far too low. (<1.4V/Cell) 2. Internal fuse tripped.	1. Contact repair center for replacing the fuse. 2. Re-charge battery. 3. Replace battery.
Mains exist but the unit works in battery mode.	Input voltage is displayed as 0 on the LCD and green LED is flashing.	Input protector is tripped	Check if AC breaker is tripped and AC wiring is connected well.
	Green LED is flashing.	Insufficient quality of AC power. (Shore or Generator)	1. Check if AC wires are too thin and/or too long. 2. Check if generator (if applied) is working well or if input voltage range setting is correct. (UPS=Appliance)
	Green LED is flashing.	Set "Solar First" as the priority of output source.	Change output source priority to Utility first.
When the unit is turned on, internal relay is switched on	LCD display and LEDs are flashing	Battery is disconnected.	Check if battery wires are connected well.
Buzzer beeps continuously and red LED is on.	Fault code 07	Overload error. The inverter is overload 105% and time is up.	Reduce the connected load by switching off some equipment.
		If PV input voltage is higher than specification, the output power will be derated. At this time, if connected loads are higher than derated output power, it will	Reduce the number of PV modules in series or the connected load.
	Fault code 05	Output short circuited.	Check if wiring is connected well and remove abnormal
		Temperature of internal converter component is over	Check whether the air flow of the unit is blocked or whether the ambient temperature is too high.
	Fault code 02	Internal temperature of inverter component is over	
	Fault code 03	Battery is over-charged.	Return to repair center.
		The battery voltage is too high.	Check if spec and quantity of batteries are meet requirements.
	Fault code 06	Output abnormal (Inverter voltage below than 190Vac or is higher than 260Vac)	1. Reduce the connected load. 2. Return to repair center
Fault code 08/09	Internal components failed.	Return to repair center.	

Appendix: Approximate Back-up Time Table

Model	Load (VA)	Backup Time @ 12Vdc 100Ah (min)	Backup Time @ 12Vdc 200Ah (min)
1.2KW	100	618	1235
	200	259	594
	300	155	396
	400	109	271
	500	87	210
	600	65	177
	700	57	139
	800	49	109
	900	43	96
	1000	38	85
	1200	26	71

Note: Backup time depends on the quality of the battery, age of battery and type of battery. Specifications of batteries may vary depending on different manufacturers.

© Copyright 2022 TECNOWARE s.r.l. All rights reserved.
All trademarks are property of their respective owners.

TECNOWARE s.r.l.
Via Montetrini, 2E - Molino del Piano - Florence - Italy
www.tecnoware.com

This manual has been printed and edited by TECNOWARE s.r.l.
June 2022 Edition - Version 1.0



TECNOWARE®
ITALIAN POWER SYSTEMS

TECNOWARE s.r.l.
www.tecnoware.com